

# Miniature Proportional Valve



## Inline Mount Version



## Manifold Mount Version

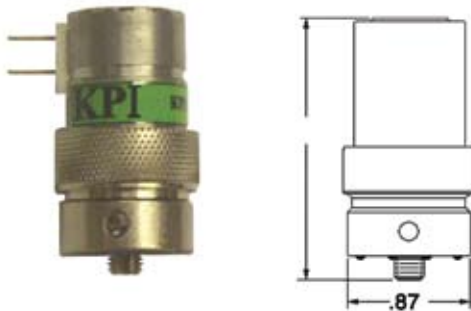

## Pipe Thread Mount Version

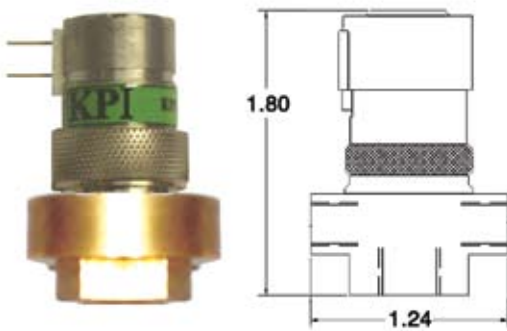

\* All Dimensions are in inches

Kelly Pneumatics, Inc. offers a low volume flow Miniature Proportional Valve. This non-spool valve architecture employing one moving part ensures virtually frictionless performance and longevity tested at over 100 million cycles. This simplicity in design also assures relative ease when implementing maintenance or cleaning. We also offer alternate versions that are resistant to both high and low temperatures, therefore performing consistently in many different environments. Available in both 2-way and 3-way versions, this valve can efficiently process Water, Air, Oil and Hydrogen. Usually used for flow parameters of 0 to 23.5 slpm.

**Valve Type:** 2-way and 3-way,  
Normally Closed

**Power Consumption:** 1.9 watts, 2.3 watts max

**Voltage Range:** 0-5, 0-10, or 0-20 volts (VDC)

**Working Pressure:** 25, 50, or 100 PSIG

**Orifice Size:** .009", .013", .025", .040" or .060"

**Port Types:** #10-32 Inline (Base Mount),  
#10-32 Manifold Mount, or pipe threads  
(1/8" and 1/16", 1 in and 2 out, respectively)

**Medium:** Air, Water, Other Gases and Liquids

**Seal Type:** Buna-N, Viton, or EPDM

**Temperature Range:** 32° - 120°F (0° - 50°C)

**Maximum Hysteresis:** 10% of full current

**Response Time:** 3 to 5 ms

**Weight:** 0.125 lbs

**Flow:** 0-500 MLPM of water,  
0-20 SLPM of air

## Typical Performance Characteristics

(Note: a 20 VDC rated valve at 10 PSIG inlet)

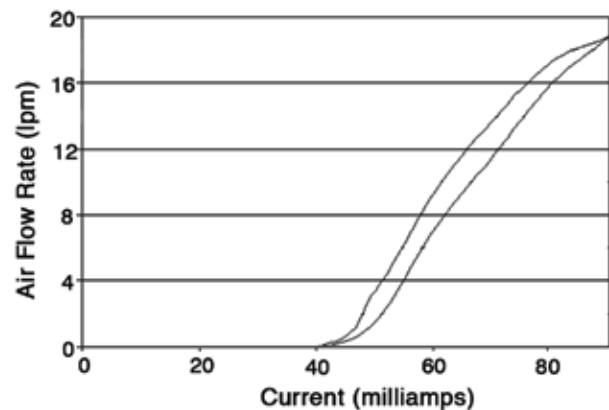
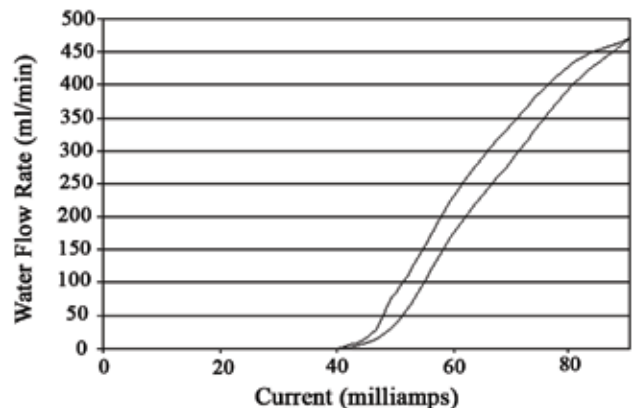

# Miniature Proportional Valve



## Inline Mount Dimensions

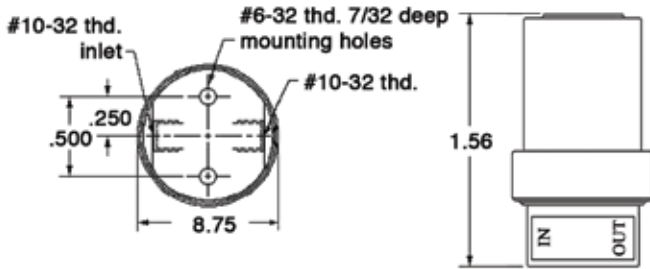

## Manifold Mount Dimensions

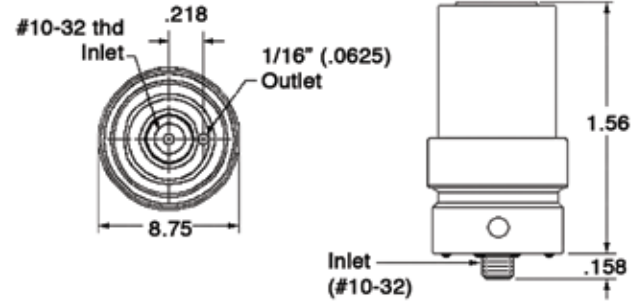

## Pipe Thread Mount Dimensions

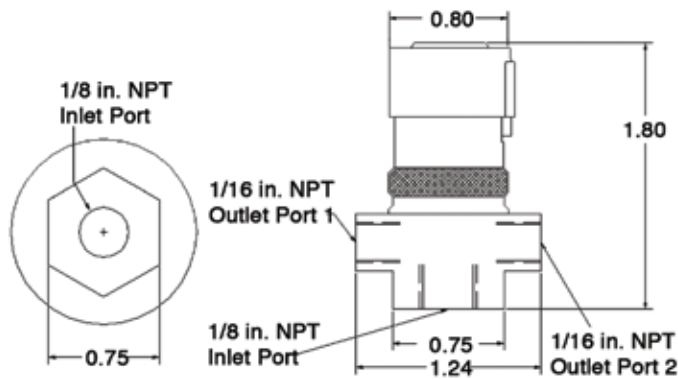

## Pipe Thread Mount Dimensions

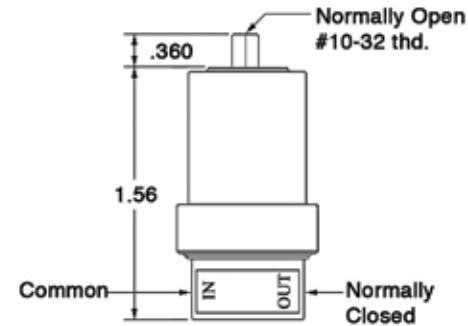

## Part Numbering System

